

Hao Yongmao, Lu Mingjing*, Dong Chengshun, Jia Jianpeng, Su Yuliang, and Sheng Guanglong

Experimental Investigation on Oil Enhancement Mechanism of Hot Water Injection in tight reservoirs

DOI 10.1515/phys-2016-0079

Received Oct 29, 2016; accepted Dec 07, 2016

Abstract: Aimed at enhancing the oil recovery of tight reservoirs, the mechanism of hot water flooding was studied in this paper. Experiments were conducted to investigate the influence of hot water injection on oil properties, and the interaction between rock and fluid, petrophysical property of the reservoirs. Results show that with the injected water temperature increasing, the oil/water viscosity ratio falls slightly in a tight reservoir which has little effect on oil recovery. Further it shows that the volume factor of oil increases significantly which can increase the formation energy and thus raise the formation pressure. At the same time, oil/water interfacial tension decreases slightly which has a positive effect on production though the reduction is not obvious. Meanwhile, the irreducible water saturation and the residual oil saturation are both reduced, the common percolation area of two phases is widened and the general shape of the curve improves. The threshold pressure gradient that crude oil starts to flow also decreases. It relates the power function to the temperature, which means it will be easier for oil production and water injection. Further the pore characteristics of reservoir rocks improves which leads to better water displacement. Based on the experimental results and influence of temperature on different aspects of hot water injection, the flow velocity expression of two-phase of oil and water after hot water injection in tight reservoirs is obtained.

Keywords: Hot water flooding; Physical simulation; Oil enhancement mechanism; Tight reservoir

PACS: 47.56.+r

***Corresponding Author: Lu Mingjing:** School of Petroleum Engineering, China University of Petroleum (East China), Qingdao, Shandong 266580, China; Email: lumingjingfy@gmail.com

Hao Yongmao, Su Yuliang, Sheng Guanglong: School of Petroleum Engineering, China University of Petroleum (East China), Qingdao, Shandong 266580, China

 © 2016 H. Yongmao *et al.*, published by De Gruyter Open. This work is licensed under the Creative Commons Attribution-NonCommercial-NoDerivs 3.0 License.

1 Introduction

Thermal recovery refers to processes of displacing oil underground by heat injecting. The thermal recovery technique is one of the most popular enhanced oil recovery methods that is usually used to improve recovery of heavy oil reservoir [1]. It mainly includes steam soaking, steam flooding, in situ combustion (ISC), hot water flooding, SAGD and electromagnetic heating [2]. Hot water flooding is widely applied because of its low heat energy loss and simple field operation, and pleasing results have been obtained in field tests.

Hot water flooding is a process whereby the hot and cold water displace the crude oil under an immiscible status [3]. The main reason that recovery ratio of heavy oil achieved by hot water injection is higher than that achieved by conventional water is its oil viscosity reduction and mobility ratio improvement [4, 5]. Under the reservoir conditions, crude oil contacts with rocks and polar material adsorbs on the surface of the rocks which determines wettability of the rocks. When the reservoir is heated by hot water, polar material in the crude oil, such as resin and asphalt desorbs merely changing the wettability of the rocks and hence making them more water wetted, so a higher recovery ratio will be obtained [6, 7]. During the development of hot-water injection, relative permeability curves will change due to the varying formation temperature, and until now, there are no unified understandings that show influence of temperature on relative permeability curves. Consequently, three views were proposed: (1) The residual oil saturation decreases and the irreducible water saturation increases with the rising temperature. Also the oil relative permeability increases and the oil-water intersection is right shifted [8–12]; (2) Tem-

Dong Chengshun: Engineering Technology Department of Liaohe Oilfield, Panjin, Liaoning 124010, China

Jia Jianpeng: Sulige Gasfield Research Center of Changqing oil field company, Xi'an, Shanxi 710018, China

perature has almost no influence on residual oil or relative permeability [13–16]; (3) For water wet rocks, the irreducible water saturation decreases and the residual oil saturation increases with rising temperature, and its relative permeability curves is left shifted [17]. Crude oil is a mixture of non-polar hydrocarbons and polar hydrocarbons such as gum and asphaltine, so temperature will certainly have a great influence on interfacial properties. Whether the interfacial tension increases or decreases with the increasing temperature depends on the composition of the fluid system, generally, it decreases with the temperature increasing [18], but there are also opposite cases [19], the decreasing of the interfacial tension is beneficial to the recovery of formation oil. Threshold pressure exists commonly in a tight reservoir, at present, most of the study is confined to the relationship between threshold pressure gradient and permeability, liquid viscosity and driving pressure gradient [20], but the influence of temperature on threshold pressure is seldom studied. The pore structure of reservoir rocks will change after long-term water flooding development because of the physical and chemical action of fluid and rocks, which will affect the displacement [21]. Additionally, with the developing of the reservoir and withdrawing of formation oil, formation energy decreases, formation pressure drops and drawdown pressure decreases, when hot water is injected, formation temperature increases, formation rocks and liquid expand with the increasing temperature [22] which is beneficial to the recovery of formation pressure.

The tight reservoir distributes widely and has abundant reserve. Compared to the high permeability reservoir, its pore structure is more complicated, reservoir physical property and plane/vertical heterogeneity are worse. Though rich experience and some achievements of tight reservoirs have been acquired after much development over the years [23–25], the recovery ratio by conventional water flooding is still very low and the overall development effect is poor. Investigation of the thermal recovery technique indicates that hot water flooding is an effective EOR method in a low permeability and low oil viscosity reservoir. Hot water injection can decrease oil viscosity and oil/water interfacial tension, expand the swept area of water flooding and improve the effect of the oil displacement, meanwhile, fluid and rocks underground are thermally expanded when heated, which plays an important role in the recovery of the formation pressure.

At present, there is no systematic research on mechanism and technique of hot water flooding in tight reservoirs and no relevant field tests have been done yet. Therefore, in this work, materials of tight reservoir oilfield are used to study the influence of hot water injection on crude

oil properties, and interactions between rock and fluid and petrophysical property in the laboratory. EOR mechanisms of hot water flooding in tight reservoirs are also analyzed, based on the enhancement mechanism, and taking the influence of temperature on the main parameters into account, expression of flow velocity in two-phase of oil and water is obtained. The study provides a theoretical basis and technical support for development of hot injection in tight reservoirs.

2 Experimental equipment and conditions

The HWGX-60 Mercury-free P.V.T. Analyzer, LCN-III HTHP Falling Ball Viscometer, Texas-500 Spinning Drop Tensiometer and HDQT-40 HTHP Multi-Function Displacement Devices are the main components of the experimental setup. Tight reservoir cores of Changqing Oilfield are chosen as experimental cores. Formation water of the Changqing Oilfield is used with salinity of 100935mg/L. The simulated oil is obtained by mixing wellhead oil and gas samples of Changqing Oilfield.

Reservoir conditions are chosen as follow: average porosity is 11.83% and average permeability is 0.38 mD. The formation pressure is 16.1 MPa, formation temperature is 70.1°C, formation oil viscosity is 0.93 mPa·s, and the bubble point is 11.3 MPa. Chang-6 reservoir is primarily a dust particle ~ fine particle arkose sandstone, clay mineral is mainly chlorite and the main pore type is intergranular pore.

3 Experiment methods and procedures

3.1 Oil samples preparation and test

The bubble point is gas/oil ratio sensitive and meets a monotone increasing function of gas/oil ratio. Generally, its accurate data can easily be obtained. Therefore, transferring oil and gas samples of different gas/oil ratio to the HWGX-60 Mercury-free PVT Analyzer allows the bubble point to be measured. The principle of matching the bubble point pressure and measuring the bubble point until it approaches the actual bubble point is utilized in this measurement. The liquid obtained can replace formation liquid reasonably well.

3.2 Experiments on effect of oil viscosity and volume factor by heat injection

We studied the effect of oil viscosity and volume factor after heat injection by measuring these parameters in the simulated oil prepared under different temperature and pressure conditions.

The experimental procedure is outlined below: (1) Keep a constant temperature and record the samples volume in the PVT container under different pressure, then change temperature and record the samples volume in the PVT container while temperature is stabilized. Calculate volume factors under different temperature and pressure (oil volume factor = the samples volume in the container / dead oil volume for samples preparation). (2) Transfer the stimulated oil to LCN-III HTHP Falling Ball Viscometer and measure its viscosity under different temperature and pressure.

3.3 Experiments on effect of oil/water interfacial tension by heat injection

The experiment tested interfacial tension between surface oil and formation water of tight reservoir under different temperatures and analyzed the effect on interfacial tension after heat injection.

To do this, the following experimental procedure was followed: (1) Test the oil and water density under different temperatures. (2) Test the refractive index of the formation water with the Abbe refractometer. (3) Test the interfacial tension under certain temperature with the Texas-500 Spinning Drop Tensiometer. (4) Change temperature and test interfacial tension under different temperature.

3.4 Experiments on effect of threshold pressure gradient by heat injection

Threshold hold pressure is usually tested from the relationship between pressure difference and flow rate in laboratory experiments.

Here below is the experimental procedure utilized in this work: (1) Test the flow velocity that liquid goes through the cores under different pressure difference. (2) Obtain the threshold pressure gradient after processing the data following the procedures of Li *et al.* (2006) [26].

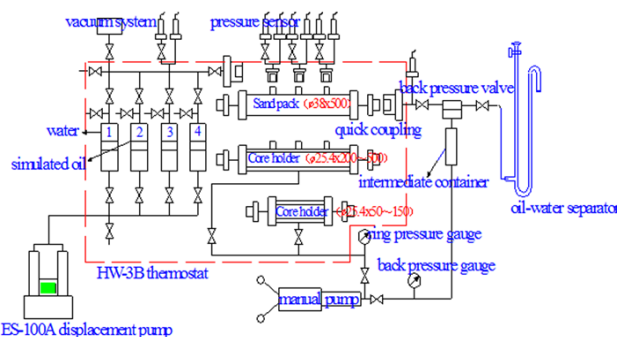

Figure 1: Flow diagram of displacement experiment

3.5 Experiments on effect of relative permeability curves by heat injection

The aim here is to measure the relative permeability curves under different temperature using the unsteady-state method and thereafter study the effect on relative permeability curves after heat injection. The experimental flow diagram is shown in Fig. 1.

A simplified verbal description of the experimental process follows: (1) Wash and dry the cores, then evacuate and saturate with underground water. (2) Set back-pressure to 14 MPa (preventing the stimulated oil from degassing and keeping the water in liquid state). (3) Consider threshold pressure gradient and measure the relative permeability curves under different temperatures following the procedures of Dong *et al.* (2007) [27].

3.6 Experiments on effect of pore structure of reservoir rock by heat injection

In order to study the effect on pore structure of reservoir after heat injection, a water displacing oil experiment and casting thin sections analysis tests are used. The procedure followed for this method is detailed below: (1) Select 25 natural tight cores from the same horizon of the same well, with the same sedimentary micro-facies and similar petrophysics. (2) Divide them into five groups to do the water displacing oil experiments under different temperatures (*i.e.* 20°C, 50°C, 90°C, 120°C, 150°C). (3) After the experiments, wash the cores and cut thin sections from these cores. (4) Then Analyze the pore structure of rocks.

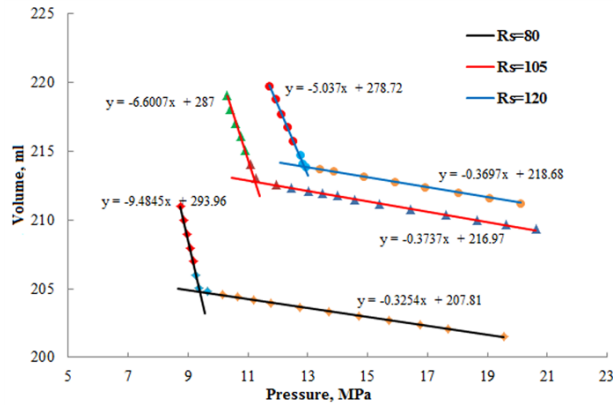

Figure 2: P-V relation curves

4 Results and discussion

4.1 Oil samples preparation and test

Compound oil and gas samples from the separator following the principle of matching the bubble point pressure. P-V relation curves of stimulated oil prepared by different gas/oil ratio under reservoir conditions (0.1°C) are shown in Fig. 2.

Corresponding pressures of the knee points on the P-V relation curves in Fig. 2 are bubble points. As can be seen from Figure 2, the bubble point is gas/oil ratio sensitive and increases as the gas/oil ratio increases. When the gas/oil ratio is 80 and 120, corresponding bubble point of the stimulated oil prepared is 9.4 MPa and 12.86 MPa, which are all improper because the bubble point provided by the oilfield is 11.3 MPa. When the gas/oil ratio is 105, the bubble point pressure is 11.2 MPa which is closest to 11.3 MPa. This thus implies that the liquid sample prepared can replace the reservoir liquid. Besides, viscosity of the liquid sample tested by the Falling Ball Viscometer is 0.9035 mPa·s (viscosity provided by the oilfield is 0.93 mPa·s), which further verified the rationality of the oil sample.

4.2 The effect on oil viscosity by heat injection

Fig. 3 shows the relation curves that viscosity changes with temperature under different pressures. Fig. 4 shows the relation curves that oil/water viscosity ratio changes with temperature under different pressures.

Fig. 3 shows that, (1) When the temperature is constant, the viscosity of simulated oil increases a little with the pressure (above the bubble point pressure) increasing,

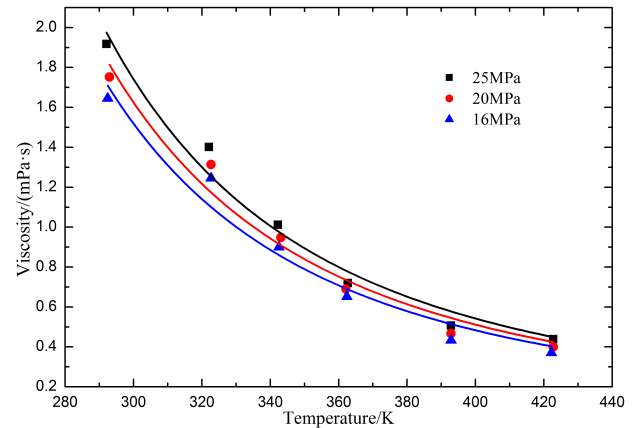

Figure 3: Curves of viscosity changes with temperature under different pressures

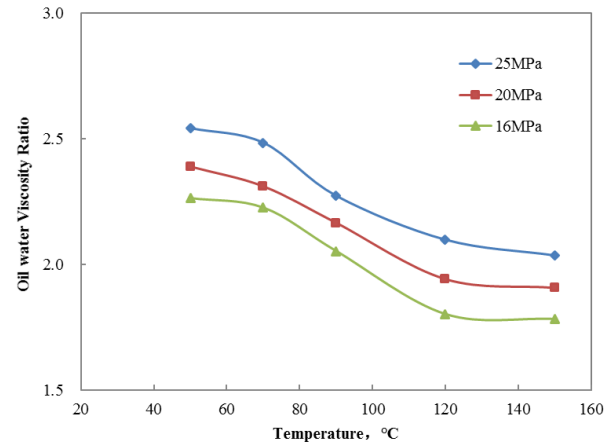

Figure 4: Curves of oil/water viscosity ratio changes with temperature under different pressures

which mainly results from the elastic compression of oil caused by the pressure increasing and then the increasing of frictional resistance between the liquid layers. (2) At a constant pressure, the viscosity of the simulated oil reduces rapidly with an increasing temperature, but the reduction gradually slows down. It is analyzed that, within a certain range, the temperature rises, distance between the oil molecules increases, intermolecular attraction decreases, frictional resistance reduces which all result in a viscosity reduction of the simulated oil, but as the temperature continues rising, increase of the distance between the oil molecules becomes slower and then the decrease of viscosity gradually slows down. Fig. 4 indicates that the oil/water viscosity ratio of tight reservoirs is very small and is only slightly affected by the temperature. It decreases slightly with the increasing temperature (viscosity of sim-

Table 1: Constants of Viscosity-Temperature Equation under different temperature

Temperature/MPa	a	b
25	0.01636	1400.2563
20	0.01597	1386.8008
16	0.01555	1374.4180

ulated oil decreases faster than water with the increasing temperature).

According to the Andrade Viscosity-Temperature Equation commonly used in calculation of thermal oil production engineering [28], the viscosity of crude oil under different pressures resulting from a temperature change is fitted. Constants under different pressures can thus be obtained from Eq (1):

$$\mu_o = ae^{b/(T-273.15)}, \tag{1}$$

where μ is viscosity, T is temperature and a, b are constants.

The results of this fitting is shown in Table 4.

Formation oil from a heavy oil reservoir has high viscosity and oil/water viscosity ratio, so the visbreaking function of thermo is the main mechanism of heat injection development. For a tight reservoir that has low viscosity, it can also enhance the oil recovery. Experiment shows that as temperature of the formation rises, the viscosity of the formation oil reduces, the viscous force decreases, flow resistance of the oil in the porous media decreases and fluidity of the oil is enhanced. There exists a threshold pressure in tight reservoirs, as temperature of the formation rises, viscosity of the formation oil reduces, threshold pressure of the oil phase becomes smaller, movable oil quantity in the reservoir increases. Oil/water viscosity ratio decreases with the temperature rising, which can reduce viscous fingering even water channeling and improve sweep efficiency.

This study indicates that as the temperature rises, the viscosity of crude oil and the oil-water mobility ratio are both reduced and oil recovery is then enhanced. But compared to the heavy oil reservoir, the oil viscosity (0.93 mPa·s) of this strata is too low and the oil/water viscosity ratio is extremely small (2.23), so the oil-water viscosity ratio decreases by very little when the temperature of the injection water rises, and moreover, the higher temperature (especially above 100°C) of the injection water, the lower the reduction rate of the oil-water viscosity ratio, which contributes little to the oil recovery.

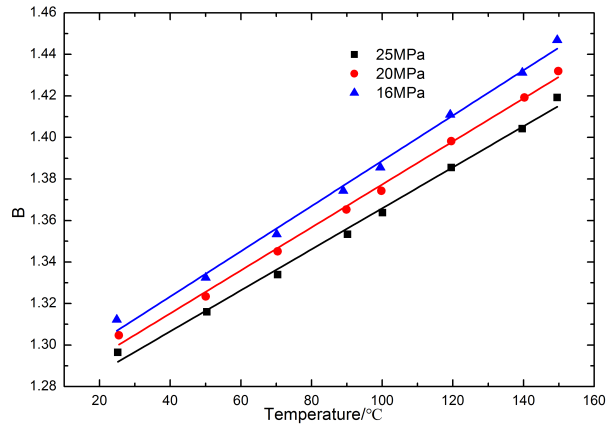

Figure 5: Curves of oil volume factor changes with temperature under different pressures

Table 2: Constants of volume factor and temperature relationship under different pressure

Pressure/MPa	c	d
25	0.000988	1.2671
20	0.00104	1.2738
16	0.00109	1.2795

4.3 The effect on oil volume factor by heat injection

Fig. 5 shows the relation curves that the oil volume factor changes with temperature under different pressures.

It can be concluded from Fig. 5 that the temperature has great influence on the oil volume factor of tight reservoirs, which is mainly due to the great thermal expansion of the large amount of natural gas dissolved in the oil. For example, when the temperature rises from 25°C to 150°C, the volume factor of the simulated oil has increased by about 10%.

The temperature and volume factor of tight reservoirs under different pressures were fitted and a fairly good linear relationship was obtained shown as Fig. 5. The relationship between volume factor and temperature is shown in Eq. (2).

$$B = c + d \times T, \tag{2}$$

where B is volume factor, T is temperature and c, d are constants.

Both the constants under different pressures in a tight reservoir are shown in Table 2.

The thermal expansion coefficient and the compressibility coefficient of crude oil can be showed as follows:

$$C_T = \frac{1}{V} \frac{dV}{dT} \tag{3}$$

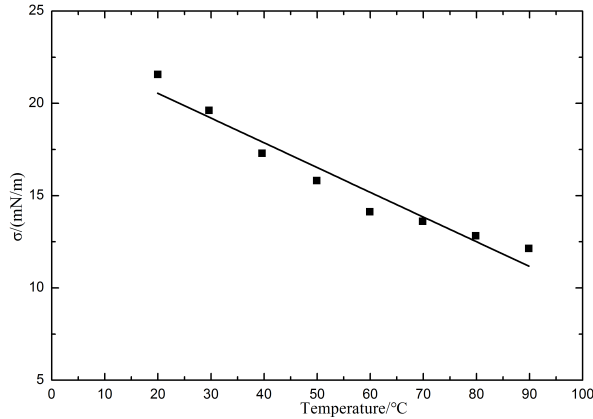

Figure 6: Curve of oil-water interfacial tension changes with temperature

$$C_P = -\frac{1}{V} \frac{dV}{dP} \quad (4)$$

Pressure change ΔP can be shown as follows (under conditions that the temperature has a change of ΔT where the volume is unchanged):

$$\Delta P = \frac{dP}{dT} \Delta T = -\frac{dP}{dV} \frac{dV}{dT} \Delta T = \frac{C_T}{C_P} \Delta T \quad (5)$$

In the developing process of the tight reservoir, the formation pressure drops quickly and it's hard to recover, so the formation pressure keeps low. The injection of hot water can enhance oil recovery because it can raise the formation temperature and the thermal expansion of the oil is profitable to the recovery of the formation pressure. Compared to the heavy oil reservoir which has a low dissolved gas/oil ratio and nonevident thermal expansion of crude oil, in this paper, the crude oil thermal expansion coefficient tested is 0.000873 (1/°C) and the compressibility coefficient tested is 0.001539 (1/MPa). Using Eq. (5) we determine that the pressure has an increase of 5.67 Mpa when the temperature rises 10°C. The thermal expansion coefficient of the rock matrix has been ignored (thermal expansion coefficient of rock matrix in tight reservoir is very small). This can highly increase the formation pressure.

4.4 The effect on oil/water interfacial tension by heat injection

Fig. 6 shows the relation curve that oil-water interfacial tension changes with temperature.

It can be seen from Fig. 6 that the oil/water interfacial tension decreases with the temperature increasing. It is analyzed that when the temperature gets higher, the molecular motion becomes violent and the oil/water sur-

Table 3: Threshold pressure of different temperature

Temperature °C	Threshold pressure gradient MPa/m
20	0.437574
50	0.203179
70	0.148784
90	0.101523

face molecular polarity difference (the molecular field) decreases, thus the oil/water interfacial tension decreases.

In water flood developing process, the oil in the rock pores is mainly affected by capillary force and viscous force. The bigger ratio of the viscous force to capillary force, the higher the oil displacement efficiency. As the temperature rises, the oil/water interfacial tension reduces and the capillary force decreases, which is beneficial in improving the recovery ratio of water flooding.

Similarly, Eq. (6) can be obtained after fitting the relationship of oil/water interfacial tension and temperature:

$$\sigma = -0.13404(T - t_0) + \sigma_{t_0} \quad (6)$$

where σ is oil/water interfacial tension, and T is temperature.

4.5 The effect on threshold pressure gradient by heat injection

Cores used in the experiments are obtained from Changqing tight reservoir, the gas log permeability is 0.655 mD, the porosity is 10.5%. Threshold pressure gradient of the oil phase (with irreducible water saturation) under different temperature tested in the experiments are shown in Table 3.

Table 1 shows that the higher the temperature is, the lower the threshold pressure gradient. The regression of experimental data is shown in Fig. 7 and regression relation is derived as:

$$G = 7.4638T^{-0.936} \quad (7)$$

As can be seen from Fig. 7, when the temperature is high, threshold pressure gradient decreases with the rising temperature and the change is steady; when the temperature drops to a certain value, threshold pressure gradient rises sharply.

When the formation temperature rises, some physical and chemical change will occur in formation rocks

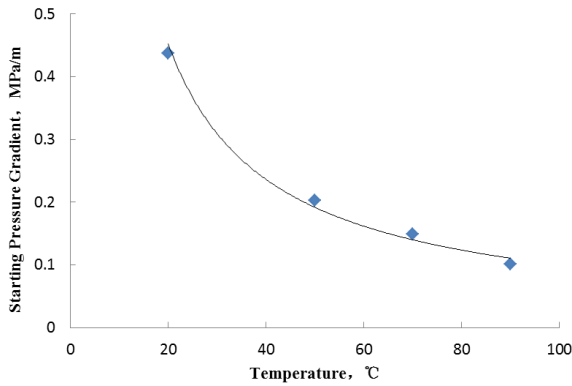

Figure 7: Curve of threshold pressure gradient versus temperature

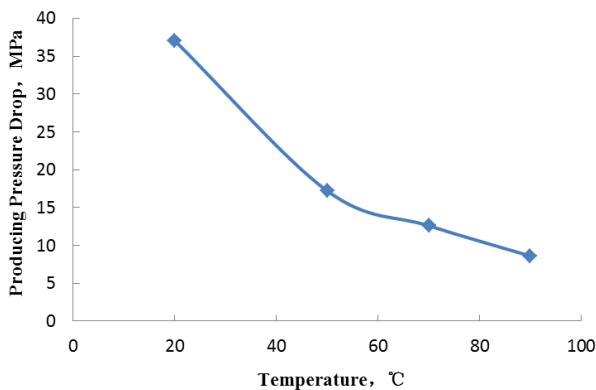

Figure 8: Curve of minimum producing pressure drop versus temperature

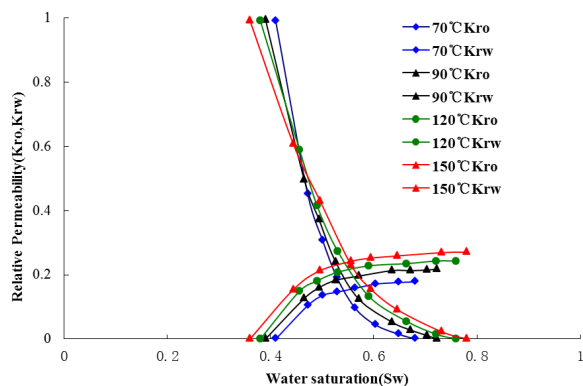

Figure 9: Comparison diagram of relative permeability curves under different temperatures

and fluid, such as changing of rock pore structure, liquid viscosity, interfacial tension force between rocks and fluid. For tight reservoir, thermal expansion coefficient of the rocks as minimal impact on the rising temperature on pore structure. The formation oil is heat sensitive, with

the temperature rising, fluid viscosity decreases sharply, viscous force turns smaller and threshold pressure gradient lows; meanwhile, the reduction of interfacial tension force between rocks and fluid and the decrease of irreducible water saturation will lead that the threshold pressure gradient turns smaller. Fig. 7 shows that changing curve of threshold pressure gradient versus temperature is similar to that of crude oil viscosity versus temperature. It is considered that change of threshold pressure gradient is mainly caused by changing viscosity of the crude oil heated.

Formation crude oil won't flow unless the driving pressure gradient is bigger than the threshold pressure gradient. According to the seepage theory, minimum producing pressure drop of certain well spacing (220 m) can be calculated from Eq. (8). Results are shown in Fig. 8.

$$\Delta P = \frac{GR \ln R/r_w}{2O} \tag{8}$$

Fig. 8 shows that if tight reservoir with the pre-existing well pattern is developed by heat injection, the minimum producing pressure drop that the formation oil needs to flow will reduce substantially, and this will relieve the situation effectively that the oil and water well “can't be injected or withdrawn”.

4.6 The effect on relative permeability curves by heat injection

Cores used in this experiment are obtained from the Changqing Oilfield, and the gas log permeability is 0.805 mD, the porosity is 10.9%. The unsteady-state method is used to get the relative permeability curves under different temperature (considering the threshold pressure gradient).

4.6.1 The effect on relative permeability curves by heat injection

The relative permeability curves under 70°C, 90°C, 120°C and 150°C are measured in the experiments. Comparing the relative permeability curves under different temperatures (Fig. 9), shows that with the temperature rising, both the oil and water relative permeability rise, and common percolation area of two phases widens. The oil-water intersection shifted to the right, which is conducive to water flooding. This change in the relative permeability curves is mainly caused by the enhanced oil-water flow ability.

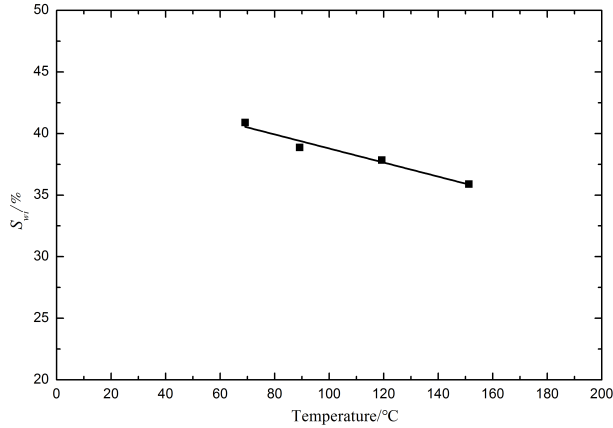

Figure 10: Curve of the irreducible water saturation changes with temperature

4.6.2 The effect on the irreducible water saturation of temperature

Fig. 10 shows curve of the irreducible water saturation of the core changing with temperature.

Fig. 10 shows that the irreducible water saturation reduces a little with the rising temperature. Reasons can be analyzed from macroscopic and microscopic views. In the macroscopic view, the irreducible water saturation is affected by both capillary force and viscous force. Cores used here are water wet, capillary force plays a role of resistance when oil displaces water, and the resistance reduces when temperature rises which results in reduction of the irreducible water saturation, besides, the viscous force between rocks and water usually reduces with the temperature rising which also results in reduction of the irreducible water saturation. In the microscopic view, the irreducible water distributes different with different wettability. While the rock surface is water wet, the irreducible water spreads on the surface of the pore as water film. When the temperature rises, the electrostatic adsorption weakens which thins the water film and then the irreducible water saturation will reduce.

The reduction of the irreducible water saturation can expand the pore space occupied by mobile liquids and raise the mobility of the formation oil, so it's beneficial to the oil recovery.

Eq. (9) can be obtained after fitting the relationship between irreducible water saturation and temperature.

$$S_{wi} = -0.05705(T - t_0) + S_{wi_{t_0}} \quad (9)$$

where S_{wi} is the irreducible water saturation, T is temperature, $S_{wi_{t_0}}$ is irreducible water saturation under temperature of t_0 .

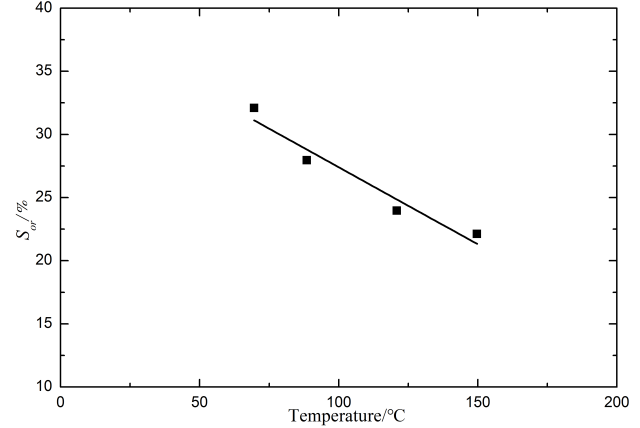

Figure 11: Curve of the residual oil saturation changes with temperature

4.6.3 The effect on the residual oil saturation of temperature

Fig. 11 shows curve of the residual oil saturation of the core changes with temperature.

From Fig. 11 we can see that the residual oil saturation reduces with the rising temperature. The main reasons for this are: (1) The flowing of oil drops in the pores depends on the pressure difference between their two ends and the extra capillary force on their meniscus, when the temperature rises, the volume factor of the simulated formation oil increases greatly, the formation pressure rises rapidly and the drive pressure difference increases, but the capillary force decreases because of the reduction of the oil/water interfacial tension, so it's beneficial to the flow and recovery of the oil. (2) The reduction of the oil/water viscosity ratio results in that the water flows forward uniformly and the waterflood front is regular, so the swept volume and displacement efficiency of water flooding increase, meanwhile, the residual oil saturation decreases.

Eq. (10) can be obtained after fitting the relationship between residual oil saturation and temperature. So that:

$$S_{or} = -0.1221(T - t_0) + S_{or_{t_0}} \quad (10)$$

where S_{or} is the residual oil saturation, T is temperature, $S_{or_{t_0}}$ is residual oil saturation under temperature of t_0 .

4.6.4 Effect on the relative permeability curves of temperature

According the experimental conditions, an implicit method was used to obtain the relative permeability. To

Table 4: Parameters of pore structure after hot water flooding of different temperature

Hot water temperature °C	Average specific surface μm^{-1}	Average pore throat ratio	Uniformity coefficient	Average pore radius μm	Sorting coefficient	Average shape factor	Sweep efficiency %
20	0.19	4.23	0.25	28.24	23.37	0.66	42.35
50	0.23	4.27	0.33	28.57	24.61	0.56	45.58
90	0.11	4.05	0.34	29.72	23.19	0.68	52.86
120	0.11	2.97	0.34	30.81	22.67	0.75	55.43
150	0.11	3.09	0.28	31.30	22.26	0.78	57.65

obtain the relative permeability functions, power law equations were used [29].

The normalized saturation S is:

$$S = \frac{S_w - S_{wi}}{1 - S_{or} - S_{wi}} \quad (11)$$

$$= \frac{S_w + 0.05705(T - t_0) - S_{wi_{t_0}}}{1 + 0.17915(T - t_0) - S_{or_{t_0}} - S_{wi_{t_0}}}$$

It is obtained that

$$k_{ro} = k_{ro}^0 (1 - S)^{n_o} \quad (12)$$

$$= k_{ro}^0 \left(1 - \frac{S_w + 0.05705(T - t_0) - S_{wi_{t_0}}}{1 + 0.17915(T - t_0) - S_{or_{t_0}} - S_{wi_{t_0}}} \right)^{n_o}$$

and

$$k_{rw} = k_{rw}^0 (S)^{n_w} \quad (13)$$

$$= k_{rw}^0 \left(\frac{S_w + 0.05705(T - t_0) - S_{wi_{t_0}}}{1 + 0.17915(T - t_0) - S_{or_{t_0}} - S_{wi_{t_0}}} \right)^{n_w}$$

Eqs (14) and (15) are based on the two equations above together with the fitting of the relative permeability curves in Fig. 9.

$$k_{ro}^0 = 0.99 \quad (14)$$

$$k_{rw}^0 = 0.21 \quad (15)$$

4.7 The effect on pore structure of reservoir rock by heat injection

Table 4 shows characteristic parameters of rock pore structure after hot water flooding under different temperatures.

As can be seen from Table 4, pore character improves with the temperature of the injected hot water rising. Changes are presented as average specific surface decreases, average pore radius increases, average pore throat ratio decreases, average shape factor increases, sorting

coefficient decreases and the uniformity coefficient increases. The main reasons are that, on one hand, it's possible that the reservoir rocks expand after being heated and with water absorption, the mechanical equilibrium is destroyed, the micro structure of the cementing material even the framework particles changes which leads to that some micro particles fall off and are carried away by the fluid; on the other hand, it may be related that the flow capacity of the fluid increased and the washing capacity is intensified.

Seepage property of tight reservoir is mainly controlled by the size of pore and throat, performance of porosity communication, size of the pore throat ratio, degree of uniformity and other factors affect the effect of water displacing oil to some extent. With small pore throat ratio, good connectivity, high degree of uniformity and uniform pore structure (single porosity type), physical property of the reservoir is good, and feature of water displacing oil presents as pistontype, sweep efficiency is high. But reservoir of poor physical property with big pore throat ratio, bad connectivity, nonuniform pore structure, the injected water pushes as approximate pistontype, but the sweeping speed is highly affected by the flow resistance and the sweep efficiency is very poor. That is to say, the better the pore character of rocks, the higher sweep efficiency of water displacing oil is. In Table 1, sweep efficiency of water displacing oil under the temperature of 20°C is 42.35%, with the temperature of the injected water rising, pore structure of rocks becomes better, and the sweep efficiency increases, when the temperature reaches 150°C, the sweep efficiency is 57.65%.

The effect of temperature on pore radius was analyzed and in Fig. 12 shows the results thereof.

Eq. (16) can be obtained from fitting the relationship of pore radius with temperature [30].

$$r = 0.02539 (T - t_0) + r_{t_0} \quad (16)$$

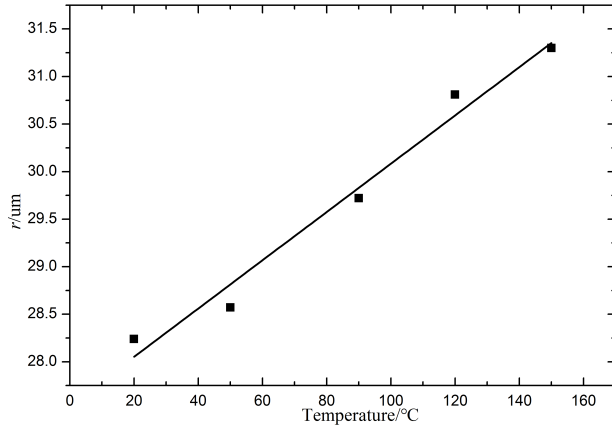

Figure 12: Relationship of pore radius and temperature in tight cores

The permeability of tight reservoirs is related to porosity and radius as Eq. (17):

$$k = \frac{r^2 \phi}{8 \tau}, \quad (17)$$

where r is pore radius and τ is tortuosity of pore and throat.

Then permeability of tight reservoir changes with temperature can be shown as Eq. (18):

$$k = k_{t_0} \left(\frac{0.02539(T - t_0) + r_{t_0}}{r_{t_0}} \right)^5 \quad (18)$$

where k_{t_0} is permeability under temperature of t_0 .

4.8 Effect on flow velocity of oil and water by temperature variation

Based on the seepage equation of oil and water and take influence of temperature on parameters into account, the expression of flow velocity in two-phase of oil and water is obtained which can be used in flow calculation with similar conditions in hot water flooding in tight reservoirs.

$$v_o = \frac{kk_{ro}}{\mu_o} (\nabla p_o - G) = \frac{k_{t_0} \left(\frac{0.02539(T-t_0)+r_{t_0}}{r_{t_0}} \right)^5}{ae^{b/(T-273.15)}} \quad (19)$$

$$\cdot \frac{k_{ro}^0 \left(1 - \frac{S_w + 0.05705(T-t_0) - S_{wi,t_0}}{1 + 0.17915(T-t_0) - S_{or,t_0} - S_{wi,t_0}} \right)^{n_o}}{ae^{b/(T-273.15)}} \cdot (\nabla p_o - 7.4638T^{-0.936})$$

$$v_w = \frac{kk_{rw}}{\mu_w} (\nabla p_w - G) = \frac{k_{t_0} \left(\frac{0.02539(T-t_0)+r_{t_0}}{r_{t_0}} \right)^5}{\mu_w} \quad (20)$$

$$\cdot \frac{k_{rw}^0 \left(\frac{S_w + 0.05705(T-t_0) - S_{wi,t_0}}{1 + 0.17915(T-t_0) - S_{or,t_0} - S_{wi,t_0}} \right)^{n_w}}{\mu_w}$$

$$\cdot (\nabla p_w - 7.4638T^{-0.936})$$

$$p_w - p_o = \frac{2\sigma}{r} = \frac{-0.26808(T - t_0) + 2\sigma_{t_0}}{0.02539(T - t_0) + r_{t_0}} \quad (21)$$

5 Conclusions

The experiments and the study in this paper lead to the following conclusions:

1. To develop tight reservoir by heat injection, once the formation is heated, crude oil viscosity and oil/water viscosity ratio will be reduced, this is beneficial in improving the waterflood effect. But when the temperature rises, it contributes little on enhanced oil recovery because the reduction of the oil/water viscosity ratio decreases by very little.
2. Volume factor of formation oil in tight reservoir increases greatly plus the big expansion coefficient of the oil with the temperature rising, which can supply the formation energy and raise the formation pressure. Oil/water interfacial tension in tight reservoirs decreases slightly but not obviously with the temperature rising, which has a certain promotion effect on production increasing. The threshold pressure gradient that crude oil starting to flow decreases with the hot-water injection, this can relieve the situation effectually that the oil and water well “can’t be injected or withdrawn”.
3. For tight reservoir, the irreducible water saturation and the residual oil saturation are both decreased with the rising temperature, two-phase percolation area is widened, the oil-water intersection shifted to the right and general shape of the curve turns better. All these are beneficial to displacement of oil by water; Pore structure of rocks in tight reservoir changes with the developing of hot-water injection, with the temperature of the injected water rising, the main pore structure improves and the effect of water displacing oil is enhanced.
4. Based on the seepage equation of oil and water and take influence of temperature on parameters into account, the expression of flow velocity in two-phase of oil and water is obtained which can be used similar conditions of hot water flooding in tight reservoirs.

Acknowledgement: Financial support provided by the Fundamental Research Funds for the Central Universities(15CX06027A), the graduate innovation fund of China

University of Petroleum (East China) under YCX2015016 and Project 51674279 supported by National Natural Science Foundation of China.

References

- [1] Alajmi A F, Gharbi R, Algharaib M. Investigating the performance of hot water injection in geostatistically generated permeable media. *Journal of Petroleum Science and Engineering*, 2009, 66(3): 143-155.
- [2] Lv G. Z and Liu X T., *et al.* Experiment on Nitrogen Hot-water Foam Flooding in Laboratory. *Journal of China University of Petroleum (Edition of Natural Science)*. 2003, 27(5):50-53
- [3] Dong X, Liu H, Zhang H, *et al.* Flexibility research of hot-water flooding followed steam injection in heavy oil reservoirs. *SPE Enhanced Oil Recovery Conference*, 19–21 July 2011, Malaysia, Kuala Lumpur
- [4] Sola B S, Rashidi F. Experimental study of hot water injection into low-permeability carbonate rocks. *Energy & Fuels*, 2008, 22(4): 2353-2361.
- [5] Tang G Q, Kovscek A R. An experimental investigation of the effect of temperature on recovery of heavy oil from diatomite. *SPE Journal*, 2004, 9(02): 163-179.
- [6] Alajmi A F F, Algharaib M K, Gharbi R C. Experimental evaluation of heavy oil recovery by hot water injection in a middle eastern reservoir. *SPE Middle East Oil and Gas Show and Conference*. Society of Petroleum Engineers, 2009.
- [7] Al-Hadhrami H S, Blunt M J. Thermally induced wettability alteration to improve oil recovery in fractured reservoirs. *SPE/DOE Improved Oil Recovery Symposium*. Society of Petroleum Engineers, 2000.
- [8] Poston S W, Ysrael S, Hossain A, *et al.* The effect of temperature on irreducible water saturation and relative permeability of unconsolidated sands. *Society of Petroleum Engineers Journal*, 1970, 10(02): 171-180.
- [9] Weinbrandt R M, Ramey Jr H J, Casse F J. The effect of temperature on relative and absolute permeability of sandstones. *Society of Petroleum Engineers Journal*, 1975, 15(05): 376-384.
- [10] Maini B B, Batycky J P. Effect of temperature on heavy-oil/water relative permeabilities in horizontally and vertically drilled core plugs. *Journal of petroleum technology*, 1985, 37(08): 1,500-1,510.
- [11] Sola B S, Rashidi F, Babadagli T. Temperature effects on the heavy oil/water relative permeabilities of carbonate rocks. *Journal of petroleum science and engineering*, 2007, 59(1): 27-42.
- [12] Hong S D and Han J W. An approach to the temperature effect on relative permeability. *Journal of China University of Petroleum (Edition of Natural Science)*. 1988. 12(4-5): 63-69 (in Chinese)
- [13] Kumar M, Inouye T A. Low-temperature analogs of high-temperature water/oil relative permeabilities. *SPE Annual Technical Conference and Exhibition*. Society of Petroleum Engineers, 1994.
- [14] Polikar M, Ferracuti F, Decastro V, *et al.* Effect of temperature on bitumen-water end point relative permeabilities and saturations. *Journal of Canadian Petroleum Technology*, 1986, 25(05).
- [15] Miller M A, Ramey Jr H J. Effect of temperature on oil/water relative permeabilities of unconsolidated and consolidated sands. *Society of Petroleum Engineers Journal*, 1985, 25(06): 945-953.
- [16] Yang L, Shen D H, Wang X D. The effect of temperature on the relative permeability and residual oil saturation. *Petroleum Exploration and Development*. 2003. 30(2): 97-99 (in Chinese)
- [17] Xuejun H, Shenglai Y, Xiaohu L, *et al.* The Effect of Temperature on Irreducible Water Saturation of Water-wet Cores. *Petroleum Science*. 2004. 1(4): 42-46.
- [18] Lo H Y, Mungan N. Effect of temperature on water-oil relative permeabilities in oil-wet and water-wet systems. *SPE Fall Meeting of the Society of Petroleum Engineers of AIME*, 30 September-3 October 1973, Las Vegas, Nevada
- [19] Hjelmeland O S, Larrondo L E. Experimental investigation of the effects of temperature, pressure, and crude oil composition on interfacial properties. *SPE Reservoir Engineering*, 1986, 1(04): 321-328.
- [20] Xu J, Cheng L, Zhou Y, *et al.* A new method for calculating kick-off pressure gradient in low permeability reservoirs. *Petroleum Exploration and Development*, 2007, 34(5): 594.
- [21] Hui G, Guangshou S, Jingle G. The influences of microscopic pore structure on waterflooding effectiveness in Xifeng Oilfield. *Journal of Northwest University: Natural Science Edition*, 2008, 38(1): 121-125.
- [22] Zhang Y T, *et al.* Thermal recovery. Beijing: Petroleum industry press. 2006(in Chinese)
- [23] Yuan B, Wood D A, Yu W. Stimulation and hydraulic fracturing technology in natural gas reservoirs: Theory and case studies (2012–2015). *Journal of Natural Gas Science and Engineering*, 2015 (26): 1414-1421.
- [24] Moghanloo R G, Yuan B, Ingrahama N, *et al.* Applying macroscopic material balance to evaluate interplay between dynamic drainage volume and well performance in tight formations. *Journal of Natural Gas Science and Engineering*, 2015, 27: 466-478.
- [25] R. G. Moghanloo, Y. Dadmohammadi, Bin Yuan *et al.* Applying Fractional Flow Theory to Evaluate CO₂ Storage Capacity of an Aquifer. *Journal of Petroleum Science and Engineering*, Volume 125, January 2015, Pages 154–161.
- [26] Li D P. Efficient development of low permeability oilfield. Beijing: Petroleum Industry Press. 2003(in Chinese)
- [27] Dong D, Feng W, Zhao J, *et al.* A method for relative permeability calculation considering start-up pressure gradient. *Natural Gas Industry*, 2007, 27(10): 95.
- [28] Andrade E N C. The viscosity of liquids. *Nature*, 1930, 125(3148): 309-310.
- [29] Rosenbrand E, Fabricius I L. Effect of hot water injection on sandstone permeability: an analysis of experimental literature. *SPE Europec/EAGE Annual Conference*. Society of Petroleum Engineers, 2012.
- [30] Civan F, Devegowda D, Sigal R F. Critical evaluation and improvement of methods for determination of matrix permeability of shale. *SPE Annual Technical Conference and Exhibition*. Society of Petroleum Engineers, 2013.