

SELECTIVITY AND SPECIFICITY IN CHEMICAL REACTIONS OF CARBENE  
 AND CARBYNE METAL COMPLEXES

E. O. Fischer, Ulrich Schubert and Helmut Fischer

Technische Universität München, 8 München 2, Postfach-Nr. 20  
 24 20, FRG

Abstract - Carbene complexes of group VI B metal carbonyls react with nucleophiles by two alternate pathways, depending on the nucleophilicity of the reagent: substitution of one CO ligand or addition to the carbene carbon atom. Reactions of carbene complexes with phosphines, amines and acetylenes are discussed to illustrate the selectivity of such reactions. A second electrophilic center at the carbene moiety, such as in siloxycarbene complexes, leads to different products. With electrophiles methoxy(organyl) carbene complexes react by cleavage of the methoxy group to yield carbyne complexes. Depending on the nature of the ligand "trans" to the carbene ligand, neutral or cationic carbyne complexes are obtained. Amino(methoxy)carbene complexes (two different nucleophilic centers) yield amino(halo)carbene complexes on treatment with boron trihalides.

It is shown that four different types of products are obtained in the reactions of carbyne complexes with nucleophiles depending on the electron density at the metal center and on the nucleophilicity of the reagent.

In 1964 we published a first note on the preparation of stable transition metal carbene complexes [1]. The general principle behind was the reaction of a metal carbonyl with organolithium reagents (LiR). Nucleophilic attack of one of the CO ligands by the carbanion gave an adduct  $(CO)_nMC(OLi)R$  which subsequently could be alkylated.

First Synthesis of Stable Metal Carbene Complexes

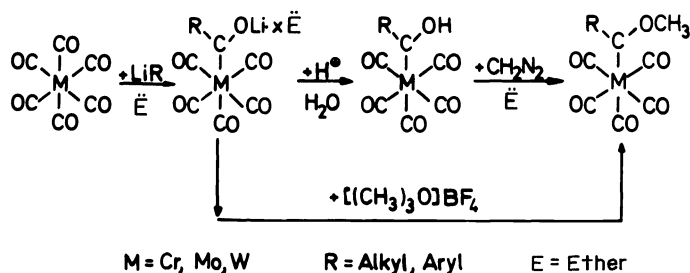

E.O. Fischer and A. Maasböl 1964

By this method a variety of carbene complexes with different metals, ligands and substituents within the carbene moiety were obtained [2]. Though several other preparative routes to carbene complexes were described in the meantime [3], mainly complexes of the type  $(\text{CO})_5\text{MC}(\text{OR})\text{R}'$  ( $\text{M} = \text{Cr}, \text{Mo}, \text{W}$ ) and  $(\pi\text{-aromat})(\text{CO})_2\text{MC}(\text{OR})\text{R}'$  ( $\text{M} = \text{Cr}, \text{W}, \text{Mn}$ ) were used for investigations concerning the reactivity of carbene complexes. Therefore I would like to limit my lecture to reactions of such complexes.

### X-Ray Structure of $(\text{CO})_5\text{CrC}(\text{OCH}_3)\text{C}_6\text{H}_5$

(pm)

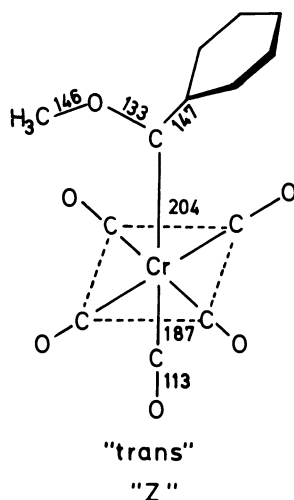

O.S. Mills and A.D. Redhouse 1968

By the X-ray structure of  $(\text{CO})_5\text{CrC}(\text{OCH}_3)\text{C}_6\text{H}_5$  [4] as an example the characteristic features of carbene complexes can be shown. The carbene C atom is surrounded by three groups [ $\text{Cr}(\text{CO})_5$ ,  $\text{OCH}_3$  and  $\text{C}_6\text{H}_5$ ]. The three bonds lie in a plane which clearly indicates a  $\text{sp}^2$ -hybridization of the carbene C atom. The bond distance between the O atom of the  $\text{OCH}_3$  group and the carbene C atom is shorter (133 pm) than a normal C-O single bond distance (143 pm) due to some  $\text{p}\pi\text{-p}\pi$  interaction. The Cr-C<sub>carbene</sub> distance is distinctly shorter than that estimated for a Cr-C single bond due to some  $\text{d}\pi\text{-p}\pi$  backbonding from filled chromium d-orbitals to the vacant p-orbital of the C<sub>carbene</sub> atom. Both the backbonding from the metal and the partial double bond to the oxygen atom are not sufficient to compensate the electron deficiency of the carbene C atom. It is therefore not surprising that the carbene carbon is liable to attack by nucleophiles.



Upon irradiation of solutions of these ylide complexes in hexane-toluene mixtures at  $-15^{\circ}\text{C}$  a CO ligand is eliminated from the cis position and thereby cis-tetracarbonyl[alkoxy(organyl)-carbene]phosphane complexes are formed [7]. When solutions of these complexes are warmed up, isomerization occurs until an equilibrium of cis and trans substituted complexes is attained. The same equilibrium mixture results on heating solutions of pentacarbonyl carbene complexes and phosphanes to  $60-80^{\circ}\text{C}$ . Substitution of a CO-ligand is usually no longer observed if an amine is taken as a nucleophile.

**Reaction of Phenylmethoxycarbene Complexes with Amines**

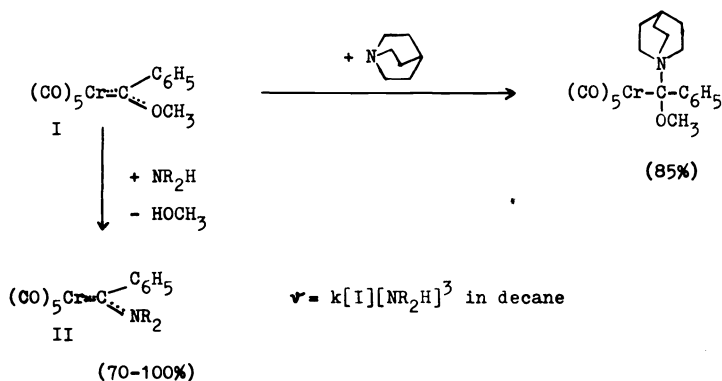

U.Klabunde and E.O.Fischer (1967), H.Werner, E.O.Fischer, B.Heckl and C.G.Kreiter (1971),  
F.R.Kreißl and E.O.Fischer (1974)

With sterically hindered tertiary amines ylide complexes are obtained in high yields analogously to the reaction with phosphanes at low temperatures [8]. With secondary and primary amines as well as ammonia the addition products no longer can be isolated. Instead of that new carbene complexes in which the amine group has replaced the methoxy group, are formed in nearly quantitative yields [9]. The aminolysis of  $(\text{CO})_5\text{CrC}(\text{OCH}_3)\text{C}_6\text{H}_5$  was studied in more detail kinetically and showed a complicated reaction type. In decane the rate law proved to be fourth order (third order in amine and first order in carbene complex) [10]. A similar nucleophilic attack at the carbene carbon atom seems to occur in the first step of the reaction of ynamines with methoxycarbene complexes, followed by a rearrangement [11].

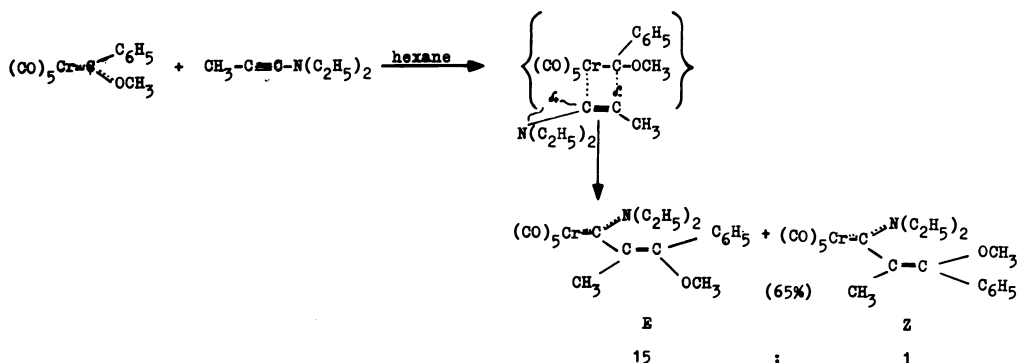
Reaction of Phenylmethoxy Carbene Complexes with Aminoacetylenes

I.H.Döts and I.Pruskil (1977)

The isolated products,  $\beta$ -methoxyalkenyl(amino)carbene complexes, can formally be regarded as insertion products of the alkyne entity into the metal-carbene bond. The formation of the olefinic bond is very stereoselective: the E/Z ratios are found to be greater than 15:1 in all cases investigated so far [11].

A less nucleophilic acetylene reacts in a totally different way. In the first step of the reaction the carbene carbon no longer is attacked by the alkyne. On the reaction of penta-carbonyl-phenyl(methoxy)carbene-chromium with pentyne(2) the alkyne, the carbene moiety and one CO group are cyclized within the coordination sphere of the metal and a  $\pi$ -naphthol complex is obtained in a kinetically controlled reaction. The incorporation of the alkyne to form the naphthol skeleton is highly stereoselective: of the possible stereo-isomers only one is formed. On warming up solutions of this naphthol complex the  $\text{Cr}(\text{CO})_3$  moiety irreversibly migrates to the unsubstituted ring [12].

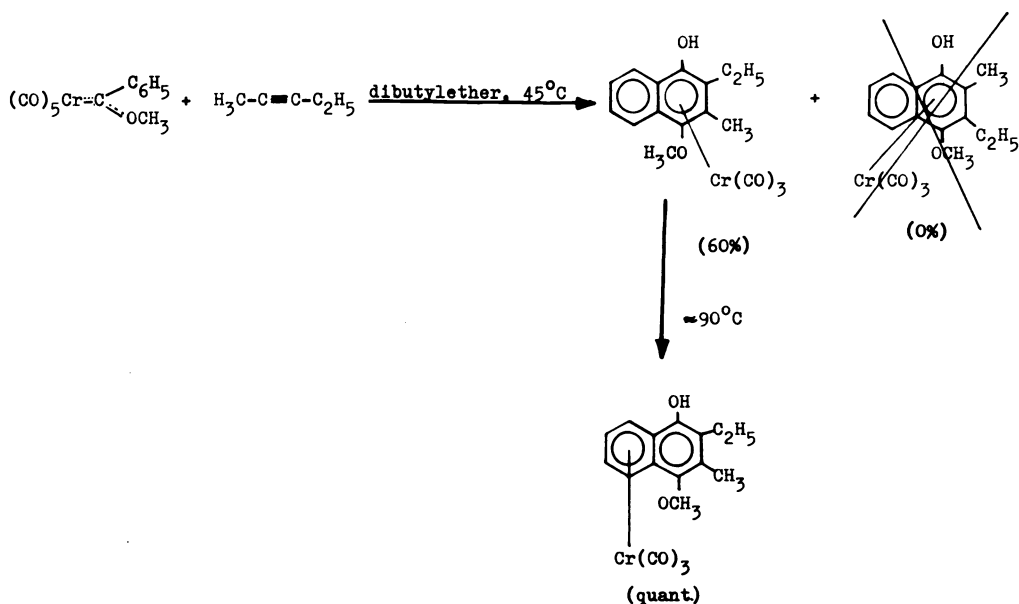
Reaction of Phenylmethoxycarbene Complexes with Acetylenes

In all reactions treated so far the carbene complexes involved had one common feature: there was only one electrophilic site within the carbene moiety. What happens if there is a second electrophilic center? Does the nucleophile attack both sites or selectively only one? There is one example found in our laboratories in the late 60's by C.G.Kreiter [13]. If methyl(alkoxy)-carbene complexes are treated with an equimolar amount of strong bases, an anion

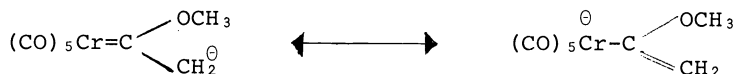

is formed. Later this anion could be isolated by C.P. Casey [14], who also used it for several synthetic applications [15]. With alkyl lithium reagents as a base only such products are found which can be derived from this type of anion. With methoxide as a base, however, both electrophilic sites are attacked. Using a catalytic amount of  $\text{CD}_3\text{O}^- \text{Na}^+$  in  $\text{CD}_3\text{OD}$  as solvent only a completely deuterated carbene complex is obtained [16].

Competition of Two Electrophilic Centers within the Carbene Moiety  
in Reactions with Nucleophiles

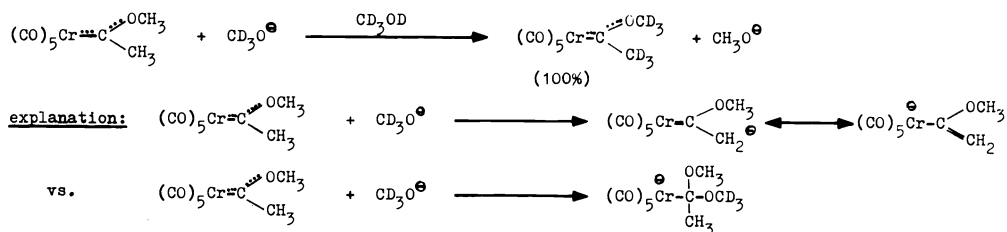

C.G.Kreiter (1968), E.O.Fischer and U.Schubert (1975)

Recently we studied trimethylsiloxy(organyl)carbene complexes, another type of carbene complex containing two electrophilic centers within the carbene moiety.

## Competition of Two Electrophilic Centers within the Carbene Moiety in Reactions with

## Nucleophiles

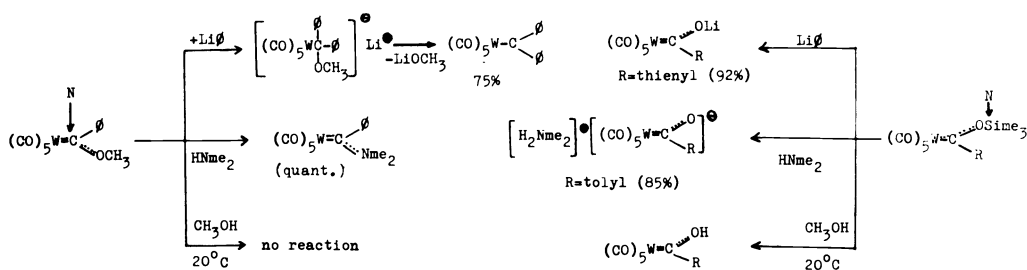

but:

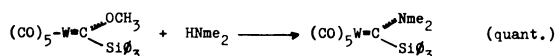

C.P. Casey and T.J. Burkhardt (1973), E.O. Fischer, W. Held and F.R. Kreißl (1976), E.O. Fischer, T. Selmayr, U. Schubert and F.R. Kreißl (1977), E.O. Fischer and H. Hollfelder (1977)

Reacting  $(\text{CO})_5\text{W}(\text{furyl})\text{OSi}(\text{CH}_3)_3$  with phenyllithium the Si-O bond is cleaved and  $(\text{CO})_5\text{W}(\text{furyl})\text{OLi}$  can be isolated in high yields [17], with R = thienyl up to 92%. On the other side analogous reaction of  $(\text{CO})_5\text{W}(\text{C}(\text{OCH}_3)\text{R})$  (R = aromatic or heteroaromatic groups) with phenyllithium yields  $(\text{CO})_5\text{W}(\text{phenyl})\text{R}$  via an adduct  $[(\text{CO})_5\text{W}(\text{C}(\text{OCH}_3)(\text{phenyl})\text{R})\text{Li}]^+$  [18]. Even weaker bases can be used to cleave the Si-O bond. With secondary amines the acylate complex  $[\text{H}_2\text{N}(\text{CH}_3)_2][(\text{CO})_5\text{W}(\text{O})\text{R}]$  is formed and with alcohols the hydroxycarbene complex  $(\text{CO})_5\text{W}(\text{OH})\text{R}$ , likely by protonation of the corresponding lithium acylate complex [17]. Alkoxy carbene complexes react with secondary amines by aminolysis as already shown, with alcohols there is no detectable reaction at ambient temperatures. These somewhat unexpected reactions of siloxycarbene complexes can be explained keeping in mind the shift of electron density from the oxygen to the carbene carbon caused by the electron deficiency of the latter atom. This removal of electron density from the oxygen should influence a neighbouring Si atom because of possible  $d\pi-p\pi$ -interactions to a much larger extent than a C atom. Therefore the Si atom can easily be attacked by nucleophiles and therefore competes successfully with the carbene carbon.

As shown so far many reactions of carbene complexes can be explained by the electron deficient nature of the carbene carbon atom. This results in a high electrophilic reactivity of the carbene carbon and may also influence neighbouring atoms. It therefore seemed to be an interesting question whether there was enough electron density left at the oxygen atom of alkoxy carbene complexes to react with electrophiles. After some unsuccessful attempts we found in 1973 that boron trihalides react rapidly already at low temperatures with pentacarbonyl-alkoxycarbene complexes of Cr, Mo and W to give a new type of organometallic compound [19].

Reaction of Phenylmethoxycarbene Complexes with Boron Trihalides as Electrophiles

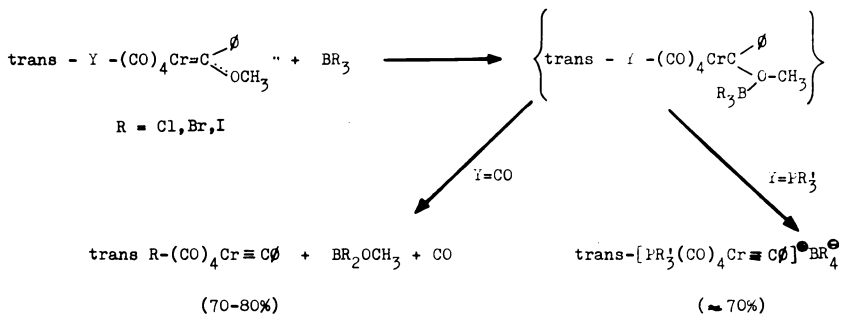

E.O.Fischer, G.Kreis, C.G.Kreiter, J.Müller, G.Huttner and H.Lorenz (1973), E.O.Fischer and K.Richter (1975)

In the initial step the boron trihalide adds to the oxygen of the alkoxy group, thus lowering or even eliminating the  $p\pi-p\pi$  -interaction between the carbene carbon and the oxygen. As a result backbonding between the metal and the carbene carbon is increased. Therefore the metal becomes electron deficient and backbonding to the carbonyl groups decreases, finally causing the splitting off of one CO ligand. Cleavage of the former  $\text{C}_{\text{carbene}}\text{-O}$  bond and incorporation of a halide anion into the complex lead to trans-halotetra-carbonylcarbyne complexes. A good indication that a trans CO group is split off was found by the following experiments: Carbyne complexes with halide and carbyne ligand still in trans position,  $\text{mer-(CO)}_3(\text{halide})(\text{phosphane})\text{Cr}\equiv\text{C-R}$ , are formed when  $\text{cis-(CO)}_4(\text{phosphane})\text{CrC(OCH}_3)\text{R}$  complexes are treated with boron trihalides [20]. With  $\text{trans-(CO)}_4(\text{phosphane})\text{CrC(OCH}_3)\text{R}$ , however, a new type of carbyne complexes is obtained, cationic  $\text{trans-}[(\text{phosphane})(\text{CO})_4\text{Cr}\equiv\text{C-R}]^+$ . The phosphane, having a higher  $\sigma$ -donor/ $\pi$ -acceptor ratio than CO, obviously is able to compensate the electron deficiency at the metal caused by removal of the  $\text{OCH}_3$  group [21]. As a representative x-ray structure of an uncharged carbyne complex,  $\text{trans-(CO)}_4(\text{I})\text{CrCCH}_3$  may be shown [22].

X-Ray Structure of  $(\text{CO})_4(\text{I})\text{CrCCH}_3$ 

(pm)

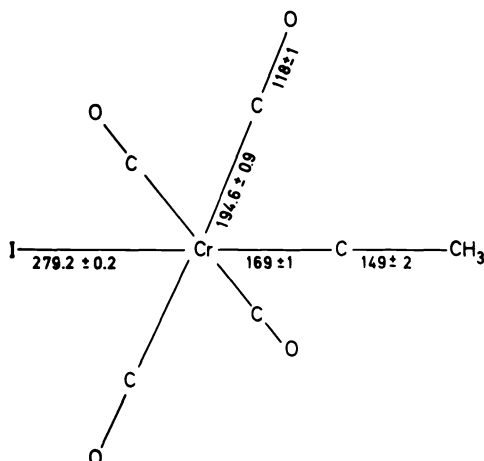

G.Huttner and W.Gartzke 1973

Carbyne complexes may also be obtained using aminocarbene instead of alkoxycarbene complexes [23]. To show whether an alkoxy or an amino group is preferably attacked by the boron trihalide we also reacted  $(\text{CO})_5\text{CrC}(\text{OCH}_3)\text{N}(\text{C}_2\text{H}_5)_2$ . With  $\text{BBr}_3$  in methylene chloride the  $\text{OCH}_3$  group and not the  $\text{N}(\text{C}_2\text{H}_5)_2$  group is cleaved off and  $\text{trans-Br}(\text{CO})_4\text{Cr}\equiv\text{C-N}(\text{C}_2\text{H}_5)_2$  is obtained [24]. We observed that the reaction proceeds via an intermediate which was very unstable under the reaction conditions employed. By utilizing  $\text{BCl}_3$  instead of  $\text{BBr}_3$  we succeeded in isolating this intermediate, which turned out to be  $(\text{CO})_5\text{CrC}(\text{Cl})\text{N}(\text{C}_2\text{H}_5)_2$  [25].

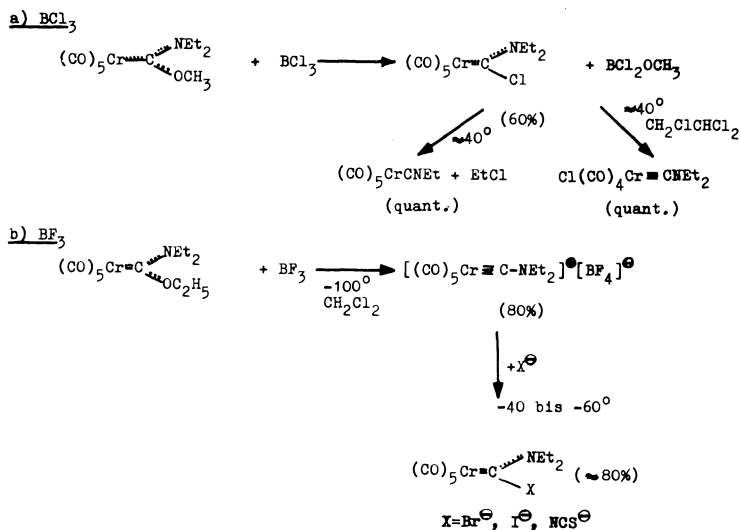
Reaction of Carbyne Complexes with two Nucleophilic Centers within the Carbene Moiety withBoron Trihalides

On warming up solutions of this new carbene complex one CO group is split off and the complex rearranges in a first order reaction to give the aminocarbene complex  $\text{trans-Cl}(\text{CO})_4\text{Cr}\equiv\text{C-N}(\text{C}_2\text{H}_5)_2$  [26]. On warming up solid  $(\text{CO})_5\text{CrC}(\text{Cl})\text{N}(\text{C}_2\text{H}_5)_2$ , however, ethyl chloride is eliminated and the isonitrile complex  $(\text{CO})_5\text{CrCNC}_2\text{H}_5$  is formed quantitatively [27]. Evidently amino(halo)carbene complexes are precursors of aminocarbene complexes. To our present knowledge we don't believe, however, that this result can be generalized for all carbene complex formation reactions. Reaction of  $(\text{CO})_5\text{CrC}(\text{OC}_2\text{H}_5)\text{N}(\text{C}_2\text{H}_5)_2$  with  $\text{BF}_3$  at  $-100^\circ$  yields a new type of cationic carbene complex,  $[(\text{CO})_5\text{Cr}\equiv\text{C-N}(\text{C}_2\text{H}_5)_2]\text{BF}_4$  [28]. The high electrophilic reactivity of the carbene carbon in this complex can be used to prepare other halo or pseudohalo carbene complexes which are not or not easily accessible by other routes. These reactions on the other side mean that a cationic carbene complex  $[(\text{CO})_5\text{Cr}\equiv\text{C-N}(\text{C}_2\text{H}_5)_2]\text{BCl}_4$  may function as an intermediate for the above described preparation of  $(\text{CO})_5\text{CrC}(\text{Cl})\text{N}(\text{C}_2\text{H}_5)_2$  [25]. Other cationic carbene complexes react with nucleophiles in an analogous way, providing a synthetically new and useful route to a wide variety of functionalized carbene complexes [29][30]. An especially convenient complex for such syntheses is  $[(\pi\text{-C}_5\text{H}_5)(\text{CO})_2\text{Mn}\equiv\text{C-}\phi]\text{BX}_4$ , which is readily accessible by reaction of  $(\pi\text{-C}_5\text{H}_5)(\text{CO})_2\text{MnC}(\text{OR}')\phi$  with boron trihalides in the above described way [29]. Some characteristic examples are summarized in the following scheme :

Reaction of Cationic Carbene Complexes with Nucleophiles

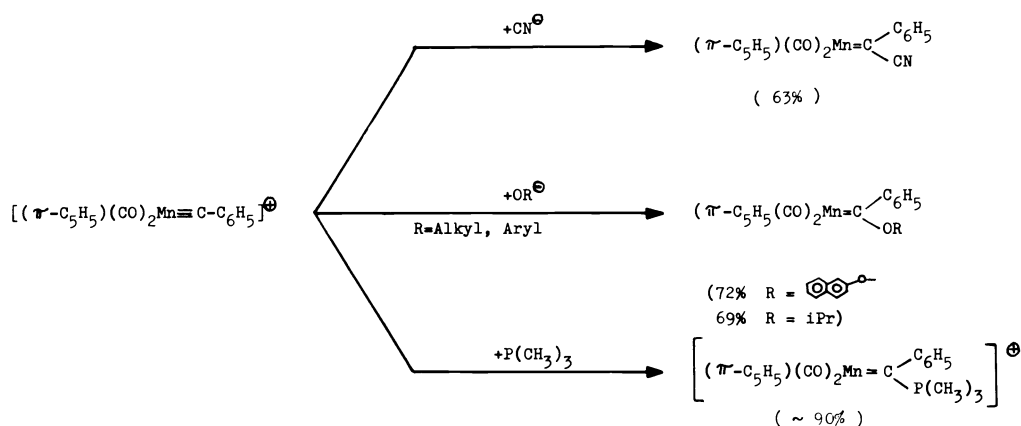

E.O.Fischer, P.Stückler and F.R.Kreibl (1977), E.O.Fischer, E.W.Meineke and F.R.Kreibl (1977),  
F.R.Kreibl, P.Stückler and E.W.Meineke (1977)

These reactions illustrate that the positive charge in such cationic carbene complexes must be localized at the carbene carbon to a very high degree. Up to now nucleophilic attack was exclusively observed at the carbene carbon atom.

This statement is no longer valid for neutral carbene complexes. For reactivity studies between  $\text{trans-halo}(\text{CO})_4\text{M}\equiv\text{C-R}$  ( $\text{M} = \text{Cr, W}$ ) and nucleophiles, phosphanes again proved to be the reagents of choice. We found that the kind of products depends on the electronic properties of the complex, the size of the metal and the nucleophilicity and steric requirements of the phosphane. Let us first consider the case when the carbene complex is kept constant and the substituents at the phosphorous atom are varied. In the first step trialkylphosphanes add to the carbene carbon of neutral carbene complexes like to that of cationic ones [31].

## Reaction of Neutral Carbyne Complexes with Phosphanes

- Dependence on the Nucleophilicity of the Phosphane -

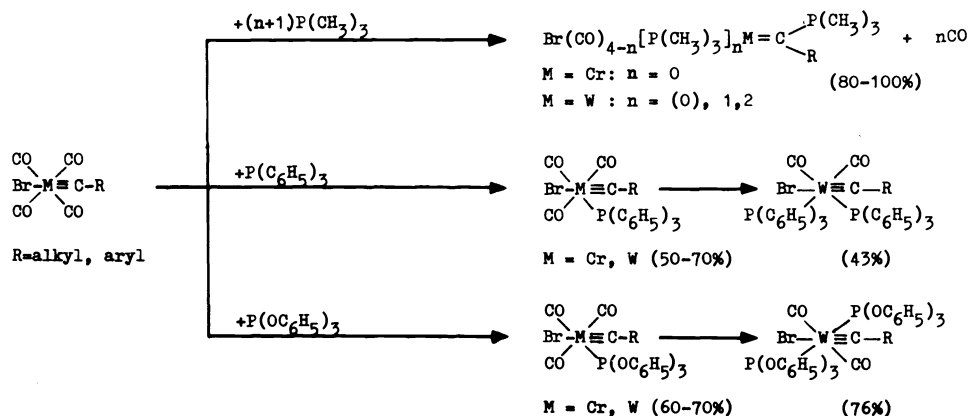

F.R.Kreibl, W.Uedelhoven and G.Kreis (1974), E.O.Fischer, A.Ruhs and F.R.Kreibl (1977)

When tungsten complexes are employed, however, there may be additionally substituted one or two CO ligands in further reaction steps [32]. Addition of the phosphane to the carbyne atom no longer is observed when less nucleophilic phosphanes are employed. Exclusively substitution of one or two CO ligands occurs with triarylphosphanes or triphenylphosphite. In most cases both mono- and disubstituted carbyne complexes can be isolated. The stereochemistry of the disubstituted complexes depends on the nature of the ligand: in the reaction with triphenylphosphite the trans isomer is found exclusively, with triarylphosphanes the cis isomer [33]. The following scheme summarizes the dependence of the products on the nature of the carbyne complex keeping the phosphane constant.

## Reaction of Carbyne Complexes with Phosphanes

- Dependence on the Metalcarbonyl Moiety -

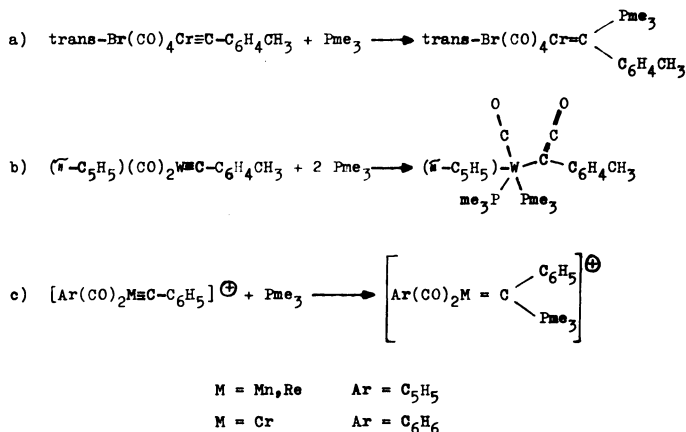

a) F.R. Kreibl (1974)      b) F.R. Kreibl et.al. (1976)

c) F.R. Kreibl, P. Stückler and E.W. Meineke (1977)

As already mentioned trimethylphosphane reacts with  $\text{trans-Br(CO)}_4\text{Cr}\equiv\text{C-aryl}$  or  $[(\pi\text{-aryl})(\text{CO})_2\text{M}\equiv\text{C-C}_6\text{H}_5]^\oplus$  ( $\text{M} = \text{Mn, Re}$ ) to give neutral or cationic metal substituted ylids, respectively. A quite different product is obtained if  $(\pi\text{-C}_5\text{H}_5)(\text{CO})_2\text{W}\equiv\text{C-C}_6\text{H}_4\text{CH}_3$  is reacted with trimethylphosphane. Formally one CO ligand migrates from the metal to the carbyne carbon and two phosphanes enter the coordination sphere of the metal. The new type of complex can be regarded as a metalized ketene [34]. So far we considered both CO substitution and attack of the carbyne atom by nucleophiles. What about the trans-positioned halide ligand in neutral carbyne complexes? It is indeed exchangeable too in a very distinct direction.

Exchange of the Group in trans Position to the Carbyne Ligand

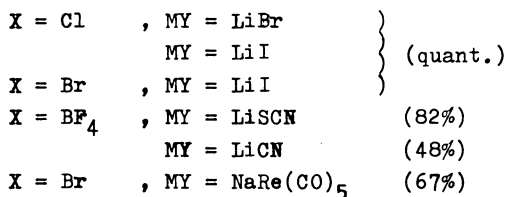
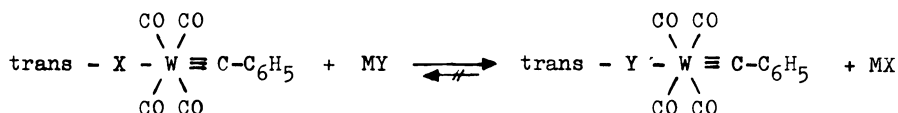

E.O. Fischer *et al.* (1976)

In etheral solutions the chloride ligand may be substituted by bromide and iodide and bromide by iodide, but not the other way round [35]. Extremely useful for such exchange experiments is  $\text{trans-(BF}_4\text{)(CO)}_4\text{Cr}\equiv\text{C-C}_6\text{H}_5$ , a very labile compound [36]. When used as a starting material even trans-cyano or trans-thiocyanato carbyne complexes can be prepared. The latter is bound via the nitrogen to the metal [37]. Even carbyne complexes with metal-metal-bonds are accessible by such exchange reactions. For instance  $\text{trans-Br(CO)}_4\text{W}\equiv\text{C-C}_6\text{H}_5$  reacts with  $\text{NaRe(CO)}_5$  to give the very stable  $(\text{CO})_5\text{Re-W(CO)}_4\equiv\text{C-C}_6\text{H}_5$  [35]. The reactions possibilities found so far can be schematically summarized in the following way:

Reaction of Carbyne Complexes with Nucleophiles

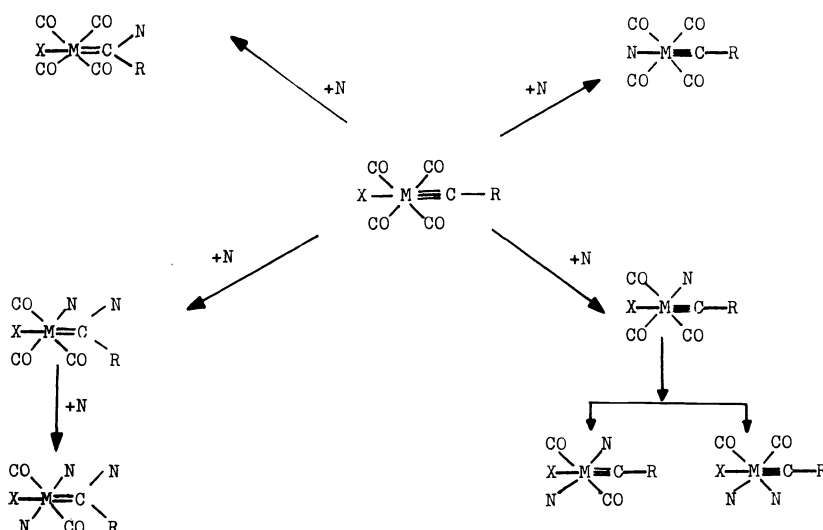

The nucleophile may add exclusively to the carbyne atom or may additionally substitute one or two CO ligands. But it may also substitute one or two CO ligands without attacking the carbyne atom. Finally the halide or pseudohalide ligand in trans position to the carbyne moiety may be substituted.

I have shown you some striking examples of stereospecific and selective reactions of carbene and carbyne metal complexes. I may finish with the remark that not all the chemistry of these species is so well understood up to now. Many problems are still waiting to be investigated in this dramatically expanding field of organometallic chemistry.

REFERENCES

1. E. O. Fischer and A. Maasböl, *Angew. Chem.* **76**, 645 (1964); *Angew. Chem. Int. Edit.* **3**, 580 (1964).
2. E. O. Fischer and A. Maasböl, *Chem. Ber.* **100**, 2445 (1967).
3. Review articles:  
E. O. Fischer, *Pure Appl. Chem.* **24**, 407 (1970); **30**, 353 (1972).  
D. J. Cardin, B. Cetinkaya and M. F. Lappert, *Chem. Rev.* **72**, 545 (1972).  
F. A. Cotton and C. M. Lukehart, *Progr. Inorg. Chem.* **16**, 487 (1972).  
D. J. Cardin, B. Cetinkaya, M. J. Doyle and M. F. Lappert, *Chem. Soc. Rev.* **2**, 99 (1973).
4. O. S. Mills and A. D. Redhouse, *J. Chem. Soc. A*, (1968) 642.
5. E. O. Fischer, *Angew. Chem.* **86**, 651 (1974).  
E. O. Fischer, *Advances in Organometallic Chemistry*, **14**, 1 (1976).
6. F. R. Kreißl, E. O. Fischer, C. G. Kreiter and H. Fischer, *Chem. Ber.* **106**, 1262 (1973).
7. H. Fischer, E. O. Fischer and F. R. Kreißl, *J. Organometal. Chem.* **64**, C41 (1974).
8. F. R. Kreißl, E. O. Fischer, C. G. Kreiter and K. Weiß, *Angew. Chem.* **85**, 617 (1973); *Angew. Chem. Int. Edit.* **12**, 563 (1973).
9. U. Klabunde and E. O. Fischer, *J. Amer. Chem. Soc.* **89**, 7141 (1967).  
E. O. Fischer, B. Heckl and H. Werner, *J. Organometal. Chem.* **28**, 359 (1971).
10. H. Werner, E. O. Fischer, B. Heckl and C. G. Kreiter, *J. Organometal. Chem.* **28**, 367 (1971).
11. K. H. Dötz, *Chem. Ber.* **110**, 78 (1977).  
K. H. Dötz and I. Pruskil, unpublished.
12. K. H. Dötz, R. Dietz, A. V. Imhof, H. Lorenz and G. Huttner, *Chem. Ber.* **109**, 2033 (1976).  
K. H. Dötz and R. Dietz, *Chem. Ber.* **110**, 1555 (1977).
13. C. G. Kreiter, *Angew. Chem.* **80**, 402 (1968); *Angew. Chem. Int. Edit.* **7**, 390 (1968).

14. C. P. Casey and R. L. Anderson, *J. Amer. Chem. Soc.* 96, 1230 (1974).
15. C. P. Casey, *J. Organometal. Chem.*, Library 1, p. 397, Elsevier Scientific Publishing Company, 1976.
16. U. Schubert and E. O. Fischer, *Lieb. Ann. Chem.* (1975) 393.
17. E. O. Fischer, T. Selmayr, F. R. Kreißl and U. Schubert, *Chem. Ber.* 110, 2574 (1977).
18. C. P. Casey and T. J. Burkhardt, *J. Amer. Chem. Soc.* 95, 8347 (1973).  
E. O. Fischer, W. Held, F. R. Kreißl, A. Frank and G. Huttner, *Chem. Ber.* 110, 656 (1977).
19. E. O. Fischer, G. Kreis, C. G. Kreiter, J. Müller, G. Huttner and H. Lorenz, *Angew. Chem.* 85, 618 (1973); *Angew. Chem. Int. Edit.* 12, 564 (1973).
20. E. O. Fischer and K. Richter, *Chem. Ber.* 109, 2547 (1976).
21. E. O. Fischer and K. Richter, *Chem. Ber.* 109, 3079 (1976).
22. G. Huttner, H. Lorenz and W. Gartzke, *Angew. Chem.* 86, 667 (1974); *Angew. Chem. Int. Edit.* 13, 609 (1974).
23. K. Weiß and E. O. Fischer, *Chem. Ber.* 109, 1868 (1976).
24. E. O. Fischer, W. Kleine and G. Kreis, *Chem. Ber.*, in preparation.
25. E. O. Fischer, W. Kleine and F. R. Kreißl, *J. Organometal. Chem.* 107, C23 (1976).
26. E. O. Fischer, W. Kleine, F. R. Kreißl, H. Fischer, P. Friedrich and G. Huttner, *J. Organometal. Chem.* 128, C49 (1977).
27. H. Fischer, unpublished.
28. E. O. Fischer, W. Kleine and F. R. Kreißl, *Angew. Chem.* 88, 646 (1976); *Angew. Chem. Int. Edit.* 15, 616 (1976).
29. E. O. Fischer, E. W. Meineke and F. R. Kreißl, *Chem. Ber.* 110, 1140 (1977).
30. E. O. Fischer, P. Stückler, H. -J. Beck and F. R. Kreißl, *Chem. Ber.* 109, 3089 (1976).  
E. O. Fischer, P. Stückler and F. R. Kreißl, *J. Organometal. Chem.* 129, 197 (1977).
31. F. R. Kreißl, *J. Organometal. Chem.* 99, 305 (1975).
32. F. R. Kreißl, W. Uedelhoven and A. Ruhs, *J. Organometal. Chem.* 113, C55 (1976).
33. E. O. Fischer, A. Ruhs and F. R. Kreißl, *Chem. Ber.* 110, 805 (1977).
34. F. R. Kreißl, A. Frank, U. Schubert, T. L. Lindner and G. Huttner, *Angew. Chem.* 88, 649 (1976); *Angew. Chem. Int. Edit.* 15, 632 (1976).
35. T. L. Lindner, *Diplomarbeit*, Techn. Univ. Munich, 1974.  
E. O. Fischer, T. L. Lindner, F. R. Kreißl and P. Braunstein, *Chem. Ber.* in press.
36. K. Richter, E. O. Fischer and C. G. Kreiter, *J. Organometal. Chem.* 122, 187 (1976).
37. S. Walz, PhD-Thesis, Techn. Univ. Munich, 1976.